

OVERPACK CONTAINER - SCC-65-OR

APPROX WEIGHT: 25.46 lbs.
DOES NOT INCLUDE WEIGHT OF POWER OR PACKAGING!!!

*** ANY ADDITIONS, DELETIONS, OR OMISSIONS MUST BE CORRECTED ON THIS DRAWING AS THIS DRAWING WILL BE CONSIDERED ALL INCLUSIVE ***

ALL GRAPHICS PROVIDED ARE FOR REFERENCE ONLY. IF CERTAIN DIMENSIONS ARE CRITICAL PLEASE VERIFY THOSE DIMENSIONS WITH YOUR SALESPERSON

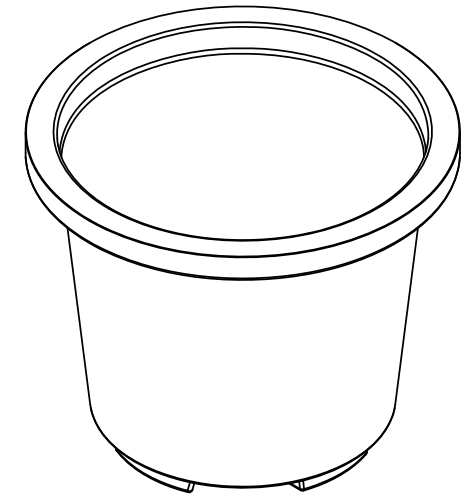
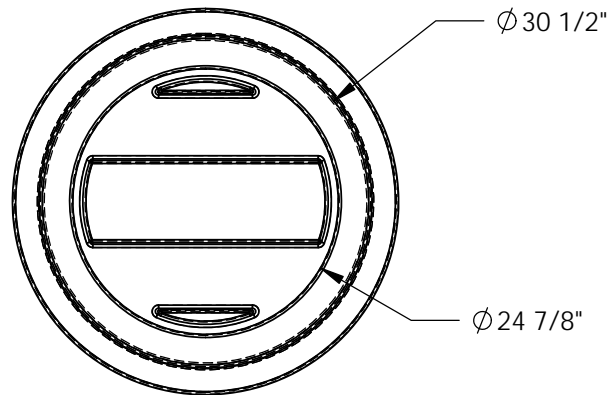
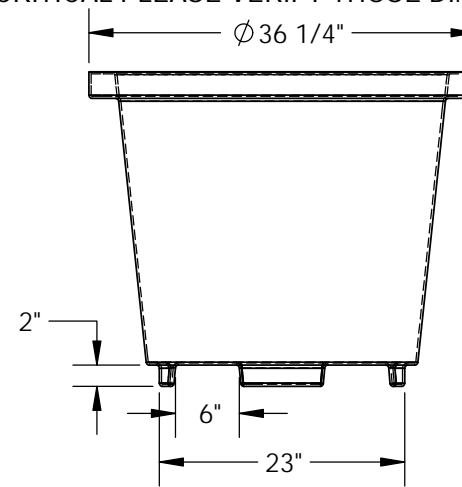
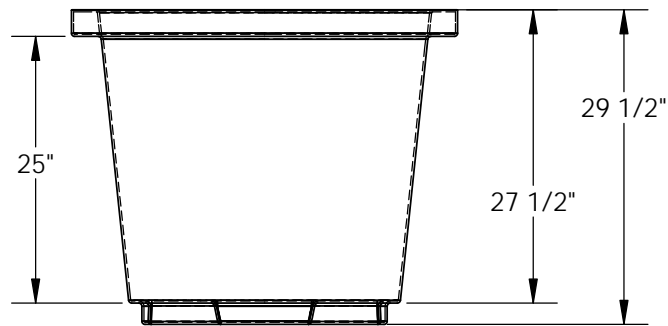

DIMENSION TOLERANCE $\pm 1/4$ "

STANDARD FEATURES

- MODEL NUMBER IS SCC-65-OR
- OVERALL DIAMETER IS $\phi 36 \frac{1}{4}$ "
- OVERALL HEIGHT IS 29 1/2"
- FORK SLOTS ARE 6" WIDE x 2" HIGH
- MADE FROM LOW-DENSITY POLYETHYLENE
- COLOR IS SAFETY ORANGE - MUNSELL, 5.0YR 6.0/15
- FOR USE WITH 55 GALLON STEEL OR PLASTIC BARRELS
- WORKS WITH DRUM-ST, DRUM-HD, AND DRUM-X-H
- MAX WEIGHT CAPACITY IS 800 LBS
- MAX VOLUME CAPACITY IS 65 GALLONS
- SNAP-ON LID (SCC-65-CVR) SOLD SEPARATELY

SPECIAL FEATURES

NONE

APPROVAL	I, THE UNDERSIGNED, AGREE THAT THE PRODUCT AS REPRESENTED SATISFIES DESIGN AND DIMENSION REQUIREMENTS. I ALSO ACKNOWLEDGE MY DUTY TO CONFIRM PRODUCT AND INSTALLATION COMPLIANCE WITH ALL APPLICABLE FEDERAL, STATE AND LOCAL REGULATIONS AND STANDARDS.	
	ANY MODIFIED UNITS ARE NON-RETURNABLE	
	[] As drawn [] As marked	
Signed: _____		Date: _____
Printed Name: _____		
LEAD TIME WILL START UPON RECEIPT OF SIGNED APPROVAL DRAWING		

FOR INTERNAL USE ONLY PROJECT SIGN OFF	
SALES	
ENG.	
FAB.	
POWER	

DISTRIBUTOR'S NAME:		P.O.#
VESTIL MANUFACTURING		X
W.O.#		X
DRAWN BY:	KGH	DATE: 8/1/2016
REFERENCE:	X	SALES: X
QUOTED LEAD TIME:	X	SCALE: 1:18
QUOTE #	X	FILE NAME:
		31-007-236-001